

#### Safety Relays

3



#### Product Description

Safety relays are intended to reliably monitor the signals from safety devices at all times and switch off quickly and reliably in an emergency. Single-channel and dual channel versions are available for the construction of safety applications. The internal logic of the safety relays monitors the safety circuits (emergency stop, guard door, and so on) and activates the enable paths in a fault-free condition. Upon actuation of the safety device or in the event of a fault, the enable paths are switched off. Any faults that occur in the control circuit, such as ground fault, cross connection fault or wire breakage are also detected.

#### Application Description

Eaton's ESR5 safety relays provide optimal safety and a high degree of reliability on plant machinery. Applications that meet the highest safety requirements in accordance with EN 954-1, EN ISO 13849-1 up to PL e and accordance with IEC 62061 up to SILCL 3 can be realized with the ESR5 safety relay.

Compatible with a wide variety of safety devices:

- Emergency stops
- Rope pulls
- Two-hand control stations
- Light curtain (OSSD)
- Gate enable device
- Safety switches

#### Contents

##### Description

	<i>Page</i>
Safety Relays	
Product Selection . . . . .	<b>V7-T3-173</b>
Technical Data and Specifications . . . . .	<b>V7-T3-174</b>
Dimensions . . . . .	<b>V7-T3-177</b>

#### Features

- Use for the highest safety requirements in accordance with EN 954-1 EN ISO 13849-1, IEC 62061 and EC 61508
- Suitable for the world market with UL, cUL certifications and TÜV Rhineland functional safety certifications
- Applicable for EN 60204 stop categories 0 or 1
- Plug-in screw terminals for fast and fault-free replacement
- Multi-voltage versions (24–230 Vac/Vdc) for a flexible range of application
- Delayed and non-delayed contact expansions accommodate a wide variety of applications

#### Standards and Certifications

- UL 508; CSA C22.2 No 14-95; CE Marked
- UL/cUL file number: E29184
- Degree of protection: IP20
- TÜV Rhineland certified
- UL/cULus listed



## Product Selection

## Safety Relays

## Technical Overview



Single Channel	Dual Channel	Safety Output (NO)	Safety Output (NO) (Delayed)	Output Delay	Signal Output (NC)	Feedback Output	Control Voltage	Removable Terminal Blocks	Type of Unit	Catalog Number
n	—	4	—	—	1	—	24 Vac/Vdc	n	Main	ESR5-NO-41-24VAC-DC
n	n	2	—	—	1	—	24 Vac/Vdc	n	Main	ESR5-NO-21-24VAC-DC
n	n	3	—	—	1	—	24 Vac/Vdc	n	Main	ESR5-NO-31-24VAC-DC
n	n	3	—	—	1	—	230 Vac	n	Main	ESR5-NO-31-230VAC
n	n	3	—	—	1	—	24–230 Vac/Vdc	n	Main	ESR5-NO-31-AC-DC
n	n	2	2	0.1–30s	—	—	24 Vdc	n	Main	ESR5-NV3-30
—	n	2	—	—	1	—	24 Vac/Vdc	n	Main	ESR5-NZ-21-24VAC-DC
n	—	5	—	—	1	1	24 Vac/Vdc	n	Expansion	ESR5-NE-51-24VAC-DC
n	—	—	4	0.3–3s	1	1	24 Vdc	n	Expansion	ESR5-VE3-42

## Application Overview

Emergency Stop	Safety Switches	Light Curtain/OSSD ①	Two-Hand Control (EN 574 Type III C)	Contact Expansion	Off-Delayed	Cross Circuit Recognition	Monitored Manual Reset ②	Catalog Number
n	n	—	—	—	—	—	—	ESR5-NO-41-24VAC-DC
n	n	—	—	—	—	n	—	ESR5-NO-21-24VAC-DC
n	n	—	—	—	—	n	—	ESR5-NO-31-24VAC-DC
n	n	—	—	—	—	n	n	ESR5-NO-31-230VAC
n	n	—	—	—	—	n	n	ESR5-NO-31-AC-DC
n	n	n	—	—	n	n	n	ESR5-NV3-30
—	n	—	n	—	—	n	—	ESR5-NZ-21-24VAC-DC
—	—	—	—	n	—	—	—	ESR5-NE-51-24VAC-DC
—	—	—	—	n	n	—	—	ESR5-VE3-42

## Application Overview, continued

Single Channel	Dual Channel	Stop Category EN 60204	Control Category to EN 954-1	Achievable PL per ISO 13849-1	Achievable SIL per EN IEC 62061	Catalog Number
n	—	0	2	PL d	SIL 3	ESR5-NO-41-24VAC-DC
n	n	0	4	PL e	SIL 3	ESR5-NO-21-24VAC-DC
n	n	0	4	PL e	SIL 3	ESR5-NO-31-24VAC-DC
n	n	0	4	PL e	SIL 3	ESR5-NO-31-230VAC
n	n	0	4	PL e	SIL 3	ESR5-NO-31-AC-DC
n	n	0/1	4	PL e	SIL 3	ESR5-NV3-30
—	n	0	4	PL e	SIL 3	ESR5-NZ-21-24VAC-DC
n	—	0	4	PL e	SIL 3	ESR5-NE-51-24VAC-DC
n	—	1	3	PL d	SIL 2	ESR5-VE3-42

## Notes

- ① Laser scanners or light curtains with OSSD outputs.  
 ② All main units can also be reset automatically or manually.

## Technical Data and Specifications

## Safety Relay

3

Description	Unit	ESR5-NO-21_	ESR5-NO-41_	ESR5-NO-31-24VAC-DC	ESR5-NZ-21_
<b>General</b>					
Standards		EN ISO 13849-1, IEC 62061, IEC 61508, DIN EN 50178, UL/CUL listed	EN ISO 13849-1, IEC 62061, IEC 61508, DIN EN 50178, UL/CUL listed	EN ISO 13849-1, IEC 62061, IEC 61508, DIN EN 50178, UL/CUL listed	EN ISO 13849-1, IEC 62061, IEC 61508, DIN EN 50178, UL/CUL listed
Type-dependent standards		—	—	—	EN 574 Part no. IIIC
Lifespan, mechanical—c (contacts)	x 10 <sup>6</sup>	10	10	10	10
Maximum operating frequency	Ops/h	3600	3600	3600	3600
Climatic proofing		Cold according to EN 60068-2-1, dry heat according to EN60068-2-2, damp heat according to EN 60068-2-3	Dry heat according to EN60068-2-2, damp heat according to EN 60068-2-3	Cold according to EN 60068-2-1, dry heat according to EN60068-2-2, damp heat according to EN 60068-2-3	Dry heat according to EN60068-2-2, damp heat according to EN 60068-2-3
Ambient temperature	°F (°C)	−4 ° to 131 ° (−20 ° to 55 °)	−4 ° to 131 ° (−20 ° to 55 °)	−4 ° to 131 ° (−20 ° to 55 °)	−4 ° to 131 ° (−20 ° to 55 °)
Ambient temperature storage	°F (°C)	−13 ° to 167 ° (−25 ° to 75 °)	−13 ° to 167 ° (−25 ° to 75 °)	−13 ° to 167 ° (−25 ° to 75 °)	−13 ° to 167 ° (−25 ° to 75 °)
Mounting position		Any	Any	Any	Any
Vibration resistance (IEC/EN 60068-2-6)		2g, frequency: 10–150 Hz, amplitude: 0.15 mm	2g, frequency: 10–150 Hz, amplitude: 0.15 mm	2g, frequency: 10–150 Hz, amplitude: 0.15 mm	2 g, frequency: 10–150 Hz, amplitude: 0.15 mm
Shock resistance (IEC 60068-2-27)		—	—	—	—
<b>Protection type</b>					
Housing		IP20	IP20	IP20	IP20
Terminals		IP20	IP20	IP20	IP20
Protection against direct contact when actuated from front (IEC 0106 Part 100)		Finger- and back-of-hand proof	Finger- and back-of-hand proof	Finger- and back-of-hand proof	Finger- and back-of-hand proof
Weight	kg	0.17	0.22	0.17	0.22
<b>Terminal capacity</b>					
Solid or flexible	mm <sup>2</sup>	1 x (0.2–2.5) 2 x (0.2–1)	1 x (0.2–2.5) 2 x (0.2–1)	1 x (0.2–2.5) 2 x (0.2–1)	1 x (0.2–2.5) 2 x (0.2–1)
Flexible with ferrule	mm <sup>2</sup>	1 x (0.25–2.5) 2 x (0.25–1)	1 x (0.25–2.5) 2 x (0.25–1)	1 x (0.25–2.5) 2 x (0.25–1)	1 x (0.25–2.5) 2 x (0.25–1)
Solid or stranded	AWG	24–12	24–12	24–12	24–12
<b>Terminal screw</b>					
Pozidriv screwdriver	Size	2	2	2	2
Flat-blade screwdriver	mm	0.6 x 3.5	0.6 x 3.5	0.6 x 3.5	0.6 x 3.5
Max. tightening torque	Nm	0.6	0.6	0.6	0.6
<b>Main Contacts</b>					
Rated impulse withstand voltage—U <sub>imp</sub>	Vac	6000	4000	4000	6000
<b>Overvoltage category/pollution degree</b>					
Outside		III/2	III/2	III/2	III/2
Inside		—	—	—	—
Rated insulation voltage—U <sub>i</sub>	Vac	250	250	250	250
Rated operating voltage—U <sub>e</sub>	Vac	230	230	230	230
<b>Rated operation current</b>					
<b>AC-15</b>					
230 V (360 ops./h)—I <sub>e</sub>	A	5	4	5	4
230 V (3600 ops./h)—I <sub>e</sub>	A	3	3	3	3
<b>DC-13</b>					
24 V (360 ops./h)—I <sub>e</sub>	A	6	4	6	4
24 V (3600 ops./h)—I <sub>e</sub>	A	3	2.5	3	2.5
<b>Max. summation current of all poles</b>					
24 Vac/Vdc devices	A	72	72	72	72
230 Vac devices	A	—	—	—	—
Square of the total current (and total current) of all current paths		72 A <sup>2</sup> (6 + 6)	72 A <sup>2</sup> (4.2 + 4.2 + 4.2 + 4.2)	72 A <sup>2</sup> (4.9 + 4.9 + 4.9)	72 A <sup>2</sup> (6 + 6)
<b>Short-circuit protection</b>					
Max. fuse	A gG/gL	10	6	10	6

## Safety Relay, continued

Description	Unit	ESR5-N0-21_	ESR5-N0-41_	ESR5-N0-31-24VAC-DC	ESR5-NZ-21_
<b>Power Supply Circuit</b>					
Actuating voltage 50/60 Hz	Vac	24	24	24	24
Actuating voltage— $U_s$	Vdc	24	24	24	24
Voltage tolerance pick-up voltage	$x_e$	0.85–1.1	0.85–1.1	0.85–1.1	0.85–1.1
Power consumption					
AC operated 50/60 Hz	VA	—	—	—	—
AC operated 50/60 Hz	W	3.4	3.4	3.4	3
DC operated	W	1.6	1.6	1.6	1.5
Fuse for control circuit supply					
24 V		Short-circuit proof	Short-circuit proof	Short-circuit proof	Short-circuit proof
115/230 V		—	—	—	—
<b>Control Circuit</b>					
Rated output voltage	Vdc	24	24	24	24
Rated operational current	mA	S12, S22: 30, S34: 45	S12: 65, S34: 40	S12, S22: 30, S34: 45	S11, S21: 60, Y2: 45
Resistance—R		50	22	50	22
Short-circuit current	A	2.3	2.3	2.3	2.3
Response time	ms	100	65	100	50
Recovery time	ms	—	—	—	—
Response time with reset monitoring— $t_{A1}$	ms	—	—	—	—
Response time without reset monitoring— $t_{A2}$	ms	100	65	100	50
Reset time— $t_R/t_{R1}$	ms	Single-channel 45; dual-channel 10	45	Single-channel 45; dual-channel 10	20
Minimum on duration— $t_M$	ms	—	—	—	—
Recovery time— $t_W$	ms	Approx. 1000	Approx. 1000	Approx. 1000	Approx. 1000
Synchronous monitoring time— $t_S$	ms	—	—	—	500
<b>Electromagnetic Compatibility (EMC)</b>					
Emitted interference		EN 61000-6-4	EN 61000-6-4	EN 61000-6-4	EN 61000-6-4
Interference immunity		According to EN 61000-6-2, EN 62061	According to EN 61000-6-2	According to EN 61000-6-2, EN 62061	According to EN 61000-6-2

# 3.10

## Control Relays and Timers

### Safety Relays

#### Safety Relay, continued

3

Description	Unit	ESR5-NO-31-230VAC	ESR5-NO-31-24V-230VAC-DC	ESR5-NV3_	ESR5-VE3_	ESR5-NE-51_
<b>General</b>						
Standards		EN ISO 13849-1, IEC 62061, IEC 61508, DIN EN 50178, UL/CUL listed	EN ISO 13849-1, IEC 62061, IEC 61508, DIN EN 50178, UL/CUL listed	EN ISO 13849-1, IEC 62061, IEC 61508, DIN EN 50178, UL/CUL listed	EN ISO 13849-1, IEC 62061, IEC 61508, DIN EN 50178, UL/CUL listed	EN ISO 13849-1, IEC 62061, IEC 61508, DIN EN 50178, UL/CUL listed
Type-dependent standards		EN 60204 (if applicable)	EN 60204 (if applicable)	EN 60204 (if applicable)	—	—
Lifespan, mechanical—c (contacts)	x 10 <sup>6</sup>	10	10	10	10	10
Maximum operating frequency	Ops/h	3600	3600	3600	900	3600
Climatic proofing		Dry heat according to EN60068-2-2, damp heat according to EN 60068-2-3	Dry heat according to EN60068-2-2, damp heat according to EN 60068-2-3	Cold in accordance with: EN 60068-2-1, dry heat in accordance with EN 60068-2-2, humidity storage test in accordance with 60068-2-78	Dry heat according to EN60068-2-2, damp heat according to EN 60068-2-3	Dry heat according to EN60068-2-2, damp heat according to EN 60068-2-3
Ambient temperature	°F (°C)	−4 ° to 131 ° (−20 ° to 55 °)	−4 ° to 131 ° (−20 ° to 55 °)	−4 ° to 131 ° (−20 ° to 55 °)	−4 ° to 131 ° (−20 ° to 55 °)	−4 ° to 131 ° (−20 ° to 55 °)
Ambient temperature storage	°F (°C)	−13 ° to 167 ° (−25 ° to 75 °)	−13 ° to 167 ° (−25 ° to 75 °)	−13 ° to 167 ° (−25 ° to 75 °)	−13 ° to 167 ° (−25 ° to 75 °)	−13 ° to 167 ° (−25 ° to 75 °)
Mounting position		Any	Any	Any	Any	Any
Vibration resistance (IEC/EN 60068-2-6)		2g, frequency: 10–150 Hz, amplitude: 0.15 mm	2g, frequency: 10–150 Hz, amplitude: 0.15 mm	2g, frequency: 10–150 Hz, amplitude: 0.15 mm	2g, frequency: 10–150 Hz, amplitude: 0.15 mm	2g, frequency: 10–150 Hz, amplitude: 0.15 mm
Shock resistance (IEC 60068-2-27)		—	—	—	—	—
<b>Protection type</b>						
Housing		IP40	IP40	IP20	IP20	IP20
Terminals		IP20	IP20	IP20	IP20	IP20
Protection against direct contact when actuated from front (IEC 0106 Part 100)		Finger- and back-of-hand proof	Finger- and back-of-hand proof	Finger- and back-of-hand proof	Finger- and back-of-hand proof	Finger- and back-of-hand proof
Weight	kg	0.3	0.3	0.17	0.17	0.22
<b>Terminal capacity</b>						
Solid or flexible	mm <sup>2</sup>	1 x (0.2–2.5) 2 x (0.2–1)	1 x (0.2–2.5) 2 x (0.2–1)	1 x (0.2–2.5) 2 x (0.2–1)	1 x (0.2–2.5) 2 x (0.2–1)	1 x (0.2–2.5) 2 x (0.2–1)
Flexible with ferrule	mm <sup>2</sup>	1 x (0.25–2.5) 2 x (0.25–1)	1 x (0.25–2.5) 2 x (0.25–1)	1 x (0.25–2.5) 2 x (0.25–1)	1 x (0.25–2.5) 2 x (0.25–1)	1 x (0.25–2.5) 2 x (0.25–1)
Solid or stranded	AWG	24–12	24–12	24–12	24–12	24–12
<b>Terminal screw</b>						
Pozidriv screwdriver	Size	2	2	2	2	2
Flat-blade screwdriver	mm	0.6 x 3.5	0.6 x 3.5	0.6 x 3.5	0.6 x 3.5	0.6 x 3.5
Max. tightening torque	Nm	0.6	0.6	0.6	0.6	0.6
<b>Main Contacts</b>						
Rated impulse withstand voltage—U <sub>imp</sub>	Vac	6000	6000	4000	4000	4000
<b>Overvoltage category/pollution degree</b>						
Outside		III/2	III/2	III/2	III/2	III/2
Inside		—	—	—	—	—
Rated insulation voltage—U <sub>i</sub>	Vac	250	250	250	250	250
Rated operating voltage—U <sub>e</sub>	Vac	230	230	230	230	230
<b>Rated operation current</b>						
<b>AC-15</b>						
230 V (360 ops./h)—I <sub>e</sub>	A	4	4	—	5	4
230 V (3600 ops./h)—I <sub>e</sub>	A	3	3	3	3	3
<b>DC-13</b>						
24 V (360 ops./h)—I <sub>e</sub>	A	4	4	—	6	4
24 V (3600 ops./h)—I <sub>e</sub>	A	2.5	2.5	3	3	2.5
<b>Max. summation current of all poles</b>						
24 Vac/Vdc devices	A	50	50	49	50	50
230 Vac devices	A	50	50	—	—	—
Square of the total current (and total current) of all current paths		50 A <sup>2</sup> (4 + 4 + 4)	50 A <sup>2</sup> (4 + 4 + 4)	50 A <sup>2</sup> (4 + 4 + 4)	49 A <sup>2</sup> (3.5 + 3.5 + 3.5 + 3.5)	50 A <sup>2</sup> (3.7 + 3.7 + 3.7 + 3.7)
<b>Short-circuit protection</b>						
Max. fuse	A gG/gL	6	6	10	10	6

## Safety Relay, continued

Description	Unit	ESR5-NO-31-230VAC	ESR5-NO-31-24V-230 VAC-DC	ESR5-NV3_	ESR5-VE3_	ESR5-NE-51_
<b>Power Supply Circuit</b>						
Actuating voltage 50/60 Hz	Vac	230	24–230	—	—	24
Actuating voltage— $U_s$	Vdc	—	230	24	24	24
Voltage tolerance pick-up voltage	$x_e$	0.85–1.1	0.85–1.1	0.85–1.1	0.85–1.1	0.8–1.1
Power consumption						
AC operated 50/60 Hz	VA	—	—	—	—	—
AC operated 50/60 Hz	W	5.8	5.8	—	—	2.2
DC operated	W	2.9	2.9	1.8	2	2.2
Fuse for control circuit supply						
24 V		—	Short-circuit proof	—	—	—
115/230 V		Short-circuit proof	Short-circuit proof	—	—	—
<b>Control Circuit</b>						
Rated output voltage	Vdc	24	24	24	24	24
Rated operational current	mA	S10, S12, S22: 35, S34, S35: 45	S10, S12, S22: 35, S34, S35: 45	S12, S22: 3.5, S34, S35: 7	A1, A2: 84, K1/K2: 5	A1, A2: 92
Resistance—R		11	11	500	—	—
Short-circuit current	A	0.7	0.7	0.1	—	—
Response time	ms	250	250	150	20	20
Recovery time	ms	—	—	—	—	—
Response time with reset monitoring— $t_{A1}$	ms	60	60	150	20	20
Response time without reset monitoring— $t_{A2}$	ms	250	250	150	20	20
Reset time— $t_R/t_{R1}$	ms	20	20	20 (non-delayed enable paths); 100 (min. delayed enable paths)	0.3–3 s (+50%) adjustable	20
Minimum on duration— $t_M$	ms	—	—	—	—	—
Recovery time— $t_W$	ms	Approx. 1000	Approx. 1000	Approx. 330	Approx. 1000	—
Synchronous monitoring time— $t_S$	ms	—	—	—	—	—
<b>Electromagnetic Compatibility (EMC)</b>						
Emitted interference		EN 61000-6-4	EN 61000-6-4	EN 61000-6-4	EN 61000-6-4	EN 61000-6-4
Interference immunity		According to EN 61000-6-2	According to EN 61000-6-2	According to EN 61000-6-2, EN 62061	According to EN 61000-6-2	According to EN 61000-6-2

## Dimensions

Approximate Dimensions in Inches (mm)

## Safety Relays, Contact Expansion Modules

## ESR5\_ 24 Vac/Vdc

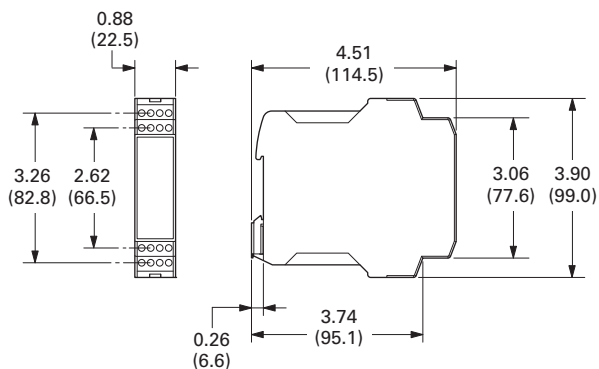

## ESR5\_ 230 Vac

